

ShuntTek heat recovery shuntgroup

Capacity range 5 – 250 kW



Benefits:

- Compact size for an easy installation and transport.
- Space and time savings during on-site installation.
- Completely mounted in case with mineral wool insulation.
- Easy to install and maintain.
- Complete with the pump, control valve and actuator.
- Possibility to choose pump model and actuator.
- Available in left-hand and right-hand versions.
- Other design can be delivered as desired.

Product information:

Prefabricated and ready-to-connect ShuntTek heat recovery shunt group is dedicated for heat recovering systems, mainly ventilation aggregates with separate coils. Standard unit is equipped with black steel P235TR1 piping and is designed to be floor mounted. Preftek uses only high quality and world recognized components, that ensures high performance during operation time. Shuntgroups comes in standard range but also is available in customized setups, easily adjusted according to the project parameters.

Technical information:

ShuntTek heat recovery shunt group technical parameters:

Type	HRSH15	HRSH20	HRSH25	HRSH32	HRSH40	HRSH50	HRSH65	HRSH80
Pipe diameter	DN15	DN20	DN25	DN32	DN40	DN50	DN65	DN80
Max flow, m ³ /h	0.3	0.6	1.3	2.2	3.5	6	11	16
Max head, kPa	230	230	230	230	230	230	230	230
Max capacity, kW	5	5-10	10-20	20-35	35-50	50-90	90-170	170-250

* Flow parameters are given at medium MEG35% and $\Delta T = 15^{\circ}\text{C}$. With other medium and ΔT meanings maximum flow parameters may vary.

Principal scheme and components:

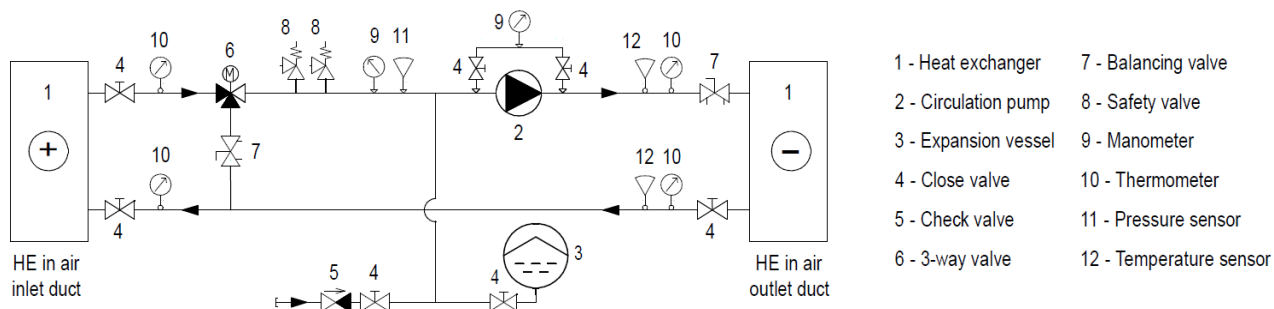

* Principal scheme shows components and operating principle of ShuntTek heat recovery shunt group.

Dimensions and weight:

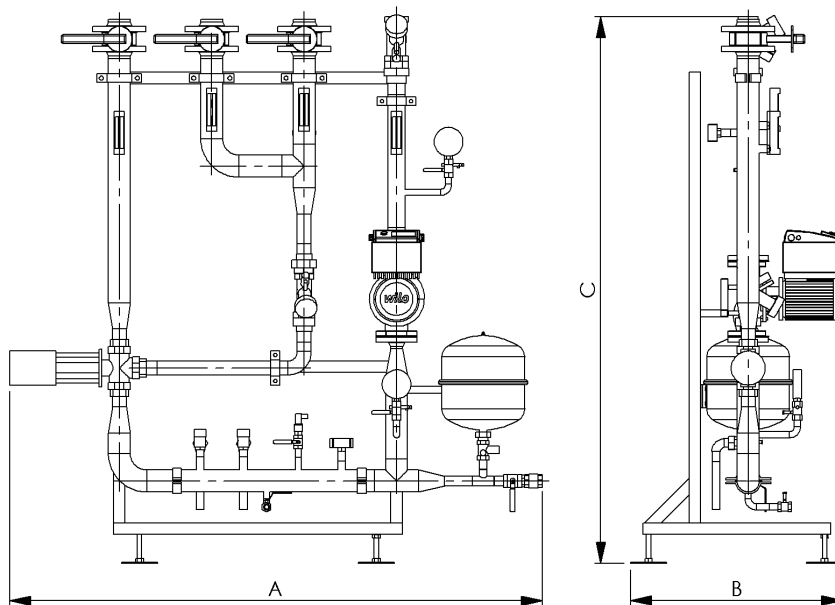

Type	HRSH15	HRSH20	HRSH25	HRSH32	HRSH40	HRSH50	HRSH65	HRSH80
A – Length, mm	1700	1700	1750	1750	1800	1800	1900	1900
B – Width, mm	650	650	650	650	750	750	750	750
C – Height, mm	1400	1450	1500	1600	1700	1800	1900	1900
Net weight, kg	110	120	130	140	150	170	200	220

* Approx. dimensions. Depending on the customer requirements, connections, type of pumps the dimensions may vary.

Installation and connection versions:

ShuntTek heat recovery shuntgroup is available in two different setups: left-hand and right-hand versions. Connections of heating, cooling sides are directly from above. Other design layouts can be ordered according to customer requirements. ShuntTek heat recovery shunt group connection points can be easily adapted to project parameters.



Left-hand version



Right-hand version